



2026 BAR-M ES-20-SL (2 Horse Slant Load Bumper Pull)

STANDARD FEATURES

Frame And Structure Standards

- Aluminum frame.
- Extruded aluminum floor.
- Aluminum side wall posts and aluminum roof bows. Side wall posts are 1 1/2" deep.
- Flooring cross members (commonly on 12" centres).
- One piece, seamless aluminum roof, with roof bows commonly on 16" centres.
- Exterior aluminum skin (White is standard. Extruded sides is an option).
- 10" up Dexter torsion axles (3,500 pounds is standard on a 2H and 5,200 on a 3H).
- (4) Steel Wheels & (1) steel wheel for spare (15" LR D).
- Spare tire installed in the dressing room (2 horse models).
- (4) Steel wheels & (1) steel wheel for spare (15" LR E).
- Spare tire installed in the dressing room (3 horse models). Electric Brakes on all axles.

Horse Area Standards

- High density, horse armour lining on all walls in horse area. Lining to be 48" tall.
- Rear load door to have horse armour lining full height on inside.
- Side access door to have rubber low and white sheet above on inside (models with access for only).
- White aluminum sheet above horse armour lining on partition wall.
- No lining or insulation above the horse armpit lining on road or curb side wall.
- Cove covers to enclose the top rail on road and curb sides of horse area.
- (1) Slim-line LED stall light per stall, installed on cove and curb side.
- Air flow dividers with stall pads on each side of every divider.
- Rubber Vet mats on floor in horse area and rear tack.
- (1) Two way roof vent per stall. Drop down feed window at head side of each stall.
- Radius, slider window at butt side of each stall. Includes bar guards.
- (2) Horse ties in horse area above each drop down feed window.
- (2) horse ties in horse area above access door (models with access door only).
- Butt strap between tack wall and curb side wall over rear load door.
- Chest strap over access door (models with access door only).
- Slider window in the rear curb side load door. Includes bar-guards.

Tack Room Standards

- (1) Slim-line LED stall light installed on cove in the tack room area.
- (1) Set of 8 bridle hooks. Installed on the road side wall in tack room.
- (1) Rear tack wall hold back (used to hold the tack wall back when tack wall is collapsed).
- Ply-felt on road side wall inside tack room area.
- Ply-felt on the inside of the road side rear door to the tack room.
- (1) Removable saddle rack with (1) saddle seat for every horse stall.
- (1) Brush box. Installed on the rear road side door near the bottom of the door.
- Tack room walls are collapsible.

Exterior Standards

- Rear doors are 60/40 with cam bars on both road and curb side rear doors.
- Full length cam bar on models with an access door in the front stall.
- Rear docking bumper below the rear doors. Running boards on road & curb sides.
- Single load light with switch in rear hoop above curb side load door (powered by recharge line).
- License plate light over the road side tack room door.
- Location for license plate on road side tack room up high.
- Complete automotive style wire harness.
- (1) Sets of LED turn/stop/tail-lights, low on each side of unit.
- (1) LED ID bar centered on rear hoop top. Left/right turn, stop, and tail lights.
- (1) Switch in rear hoop for the stall lights.
- Aluminum fender with top side mounted fender light.
- (1) Exterior horse tie per stall.
- Drop down feed window hold down, (1) at each drop down feed window.
- Door hold back on each of the rear doors and (1) at access door if applicable.
- Three piece skin coloured nose sheet. Center sheet is riveted at the seams.
- Large Bar-M nose decal. Centered on unit up, up high (centre sheet is riveted).
- (2) Red reflectors. One installed on road side rear and one on curb side rear, mid way up.
- (2) Amber reflectors. One installed on road side rear and one on curb side front, mid way up.
- (2) Amber reflectors. One on road side nose & one on curb side nose, just bellow top rail.
- Bar-M Logo on top-rail. Both road and curb sides near the rear of the trailer on the top rail.
- Bar-M Logo on curb side door down lower curb side of door.
- Red/White conspicuity tape along the entire bottom side of and curb side rear doors.
- Red/White conspicuity tape along the lower side of road and curb side walls (in sections).
- Top crank jack with wheel.
- Coupler for 2 5/16" ball. Safety cables, emergency break away battery (with charger) & switch.
- Dimond plate nose guard.
- (12) Upper clearance lights. (2) on rear, (3) on road & curb side top rail, (4) on front nose top-rail.
- (2) Lower clearance lights. Down low, (1) on curb side and (1) on road side.

Dressing Room Standards

- Custom built camper door with 20" window.
- Dressing room is a 10" short wall.
- (1) Additional saddle rack location does not include the saddle rack or saddle seats).
- Rubber on the dressing room floor.
- Break away battery bow, battery and charger installed in dressing room.
- (2) Set of (8) bridle hooks installed on partition wall up high, near curb side of unit.
- Spare tire is installed in the dressing room.
- Saddle Tier (1 per horse).

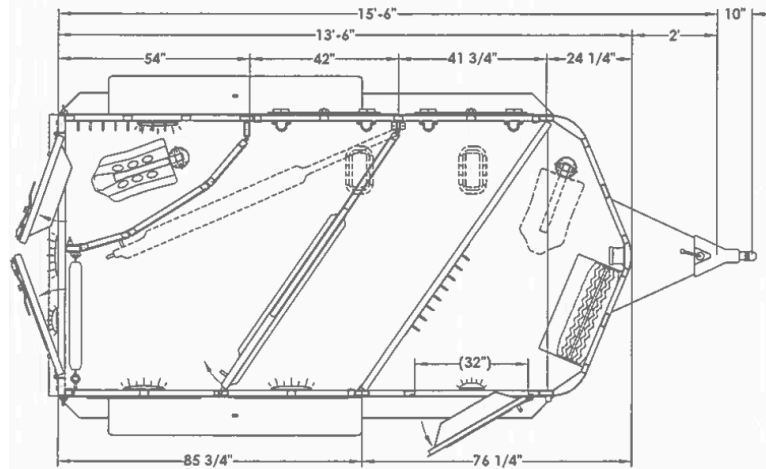

OPTIONAL EQUIPMENT ADDED

- Charcoal Skin
- Hoof Grip Flooring In Horse Area
- Rubber Mats in Dressing Room
- Bauer Cam Back Lock Box (QTY 2)
- Extruded Slat In The Horse Area
- Aluminum Wheels Upgrade
- Lower Divider On The First Divider
- Stall Width - 42"
- Stall Length - 82"

EMPTY WEIGHT - 2,500 LB
 GVWR - 7,000 LB
 LENGTH - 13'6"
 HEIGHT - 7'6"
 AXLE - (2) 3,500 LB
 WIDTH - 6'8"

CUSTOMER CARE

2-YEAR HITCH TO BUMPER WARRANTY
 8-YEAR STRUCTURAL WARRANTY

MSRP: \$43,412

\$33,799

YOUR PAYMENT

MONTHLY

\$366

TERM/AM

180/180

BI-WEEKLY

\$169

INTEREST RATE

8.99%